



Mounting Solution

Monitor Arms, Laptop Mounts
& Tablet Mounts



Dedicated in Mounting Solutions
For over 14 years

www.v-mounts.com



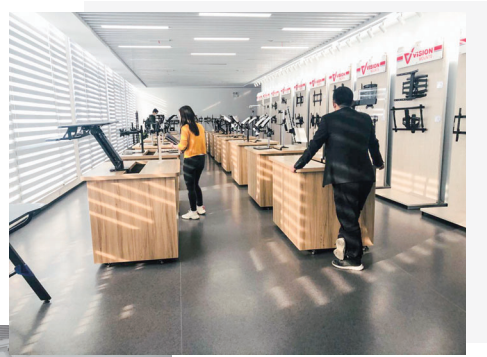

Company Introduction

Established in early 2000, Vision Mounts is a prime manufacturer who is specialized in designing and producing a comprehensive line of Universal LED/LCD Wall Mounts, Ceiling Mounts, Projector Mounts, Desktop Mounts, TV Stands, height adjustable desks, gaming desks and electric bed frame for Audio/Video applications in home or office, including user-friendly and environmental-friendly mounting solutions.

■ Engineering Capabilities

We have a dedicated R&D and Engineering team to support and to serve our customer's needs.

We introduce cutting-edge designs and state-of-the-art models annually.

■ Production Capabilities

We serve original equipment manufacturers, institutional and industrial customers, professional installers, as well as globe and national-wide retail chains.

■ Quality Assurance

As an ISO9001:2000 certified manufacturer, we have implemented the Total Quality Assurance system from raw material inspection, production processing control, to final inspection and packaging. We are committed to delivering the highest quality products that are easy to install and maintain with a competitive cost saving solutions.

We have a significant amount of products are TUV certified and comply with GS regulations.

■ Customer-Care-Services

Our devoted customer-care-service teams always ensure that your inquiries are responded in a timely fashion and your orders are on-time delivered. Customer satisfactions are guaranteed.

Trade Capacity

Having the right team involved from the beginning to the end of your project allows you to rest easy with the peace of mind knowing your investment and idea are in capable hands, VISION has the experience you need for successful product development from design, engineering, and manufacturing know how that brings your product quickly to life and into your customer's hands.

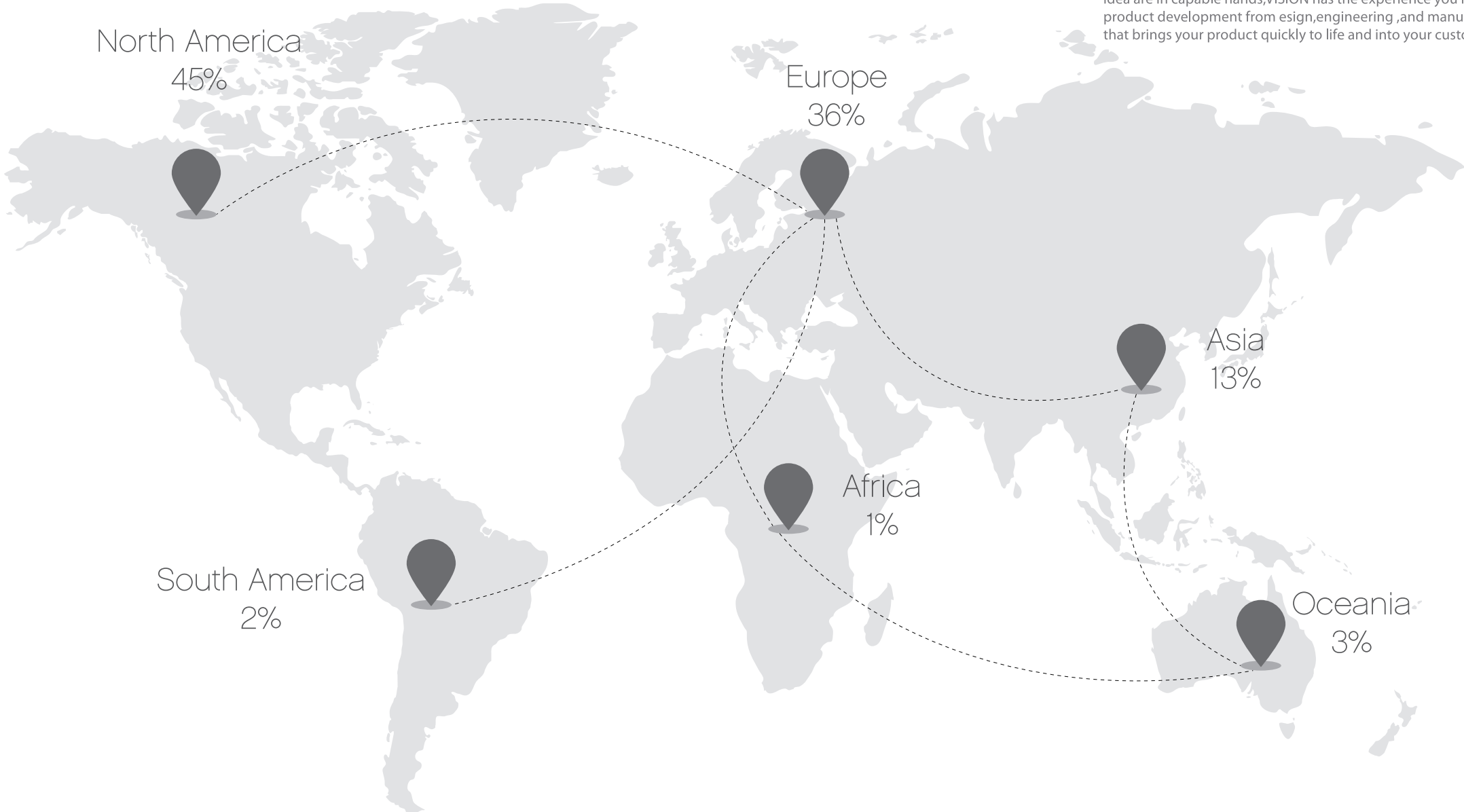

The World's Major Exhibition

We focused on supplying the innovative and affordable solution for global customers.
Simple contact us with your custom requirements. give us idea,we will give you a solution!



Hong Kong Show



Shanghai CIFF Show



China Sourcing Fair



CES Show



Guangzhou CIFF Show



Cologne, Germany Show

NEW

 **85°**

 **90°**

Gas Spring Monitor Arm

Height adjustable working experience improves your working efficiency.

VM-GE51

Screen size:15"-32"

Max load:0-8kg/0-17.6lbs

VESA:75x75/100x100



Gaming Gas Spring Monitor Arm

Suitable for gaming and all modernized scenarios.

VM-GE22

Screen size:15"-32"

Max load:0-8kg/0-17.6lbs

VESA:75x75/100x100

Die Casting Aluminum Structure!

HOT

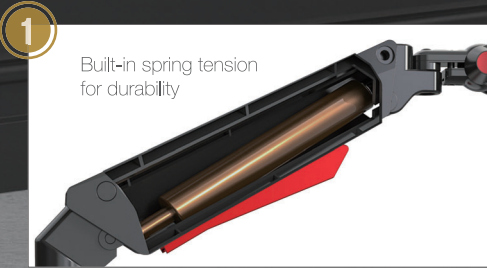
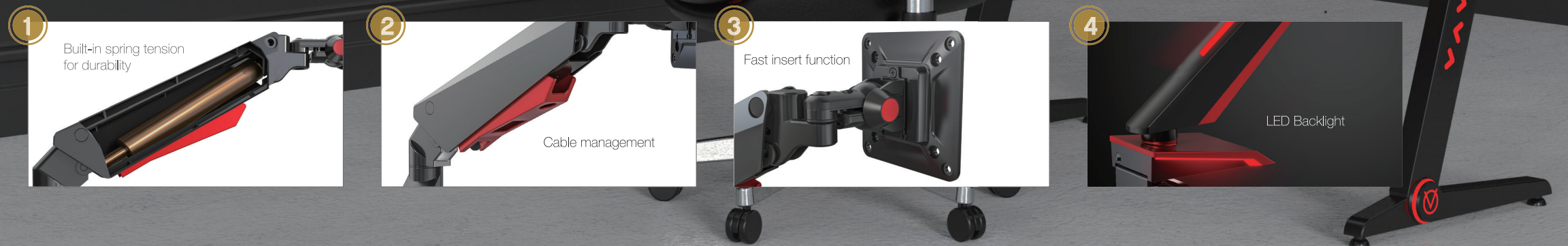

Gas Spring Monitor Arm

Height adjustable working experience improves your working efficiency.

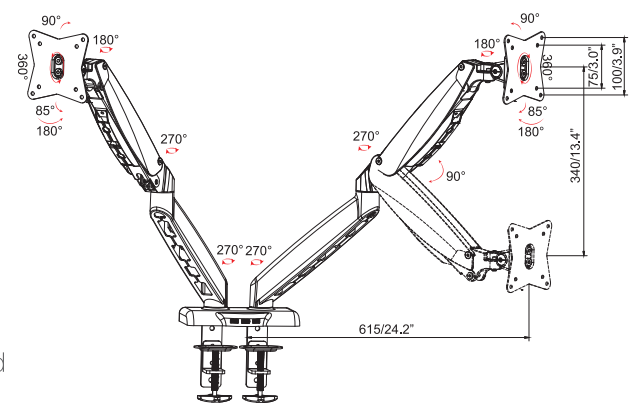
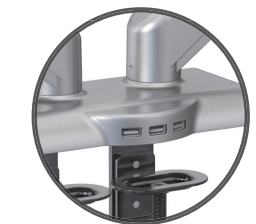
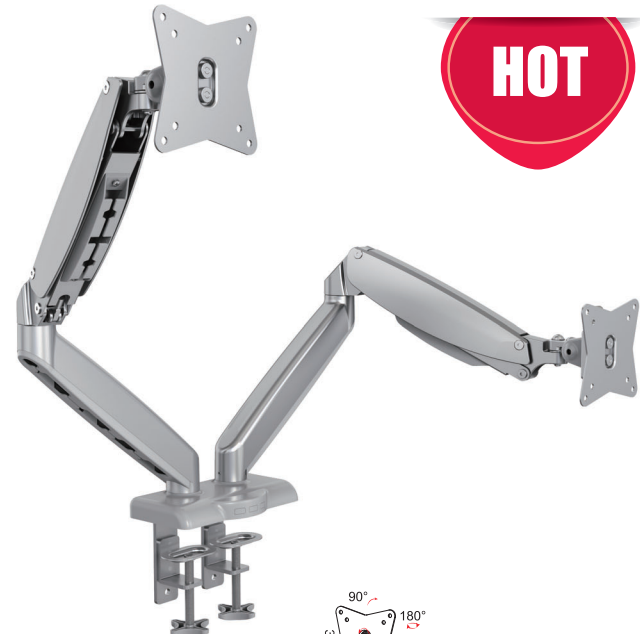
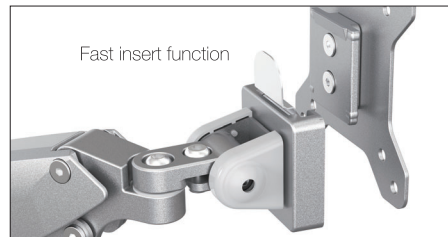

Model	VM-GE24	Features
Screen size	15"-32"	<ul style="list-style-type: none"> • Save space without replacing the original desktop • Support horizontal and vertical screen rotation • Gas spring arm with effortless height adjustment • Angle-free tilt • Aluminum Structure
Max load	0-9kg/0-19.8lbs	
VESA	75x75/100x100	
Tilt	+90°/-85°	
Swivel	180°	
Rotate	360°	



Pneumatic Arm Dual Monitor Arm

A modern product is waiting for your exploration.

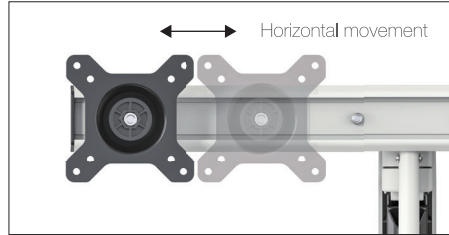

Model	VM-GF02	Features
Screen size	15"-27"	<ul style="list-style-type: none"> • Save space without replacing the original desktop • Support horizontal and vertical screen rotation • Gas spring arm with effortless height adjustment • Angle-free tilt • Aluminum Structure
Max load	2-8kg/4.4-17.6lbs	
VESA	75x75/100x100	
Tilt	+15°/-15°	
Swivel	180°	
Rotate	360°	

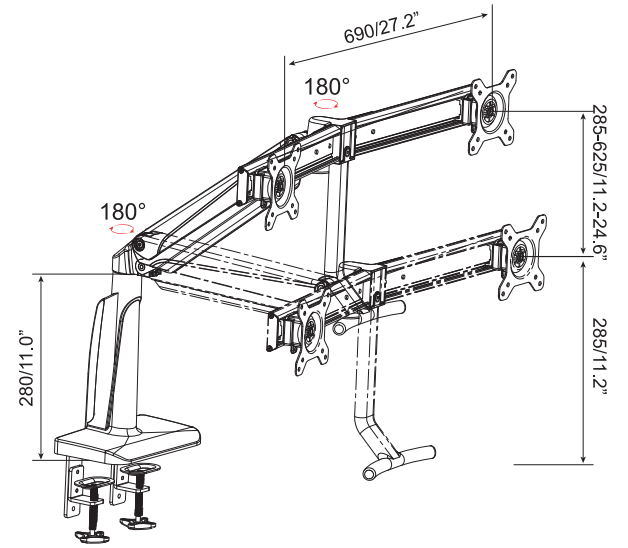

Gas Spring Monitor Arm

Height adjustable working experience improves your working efficiency.

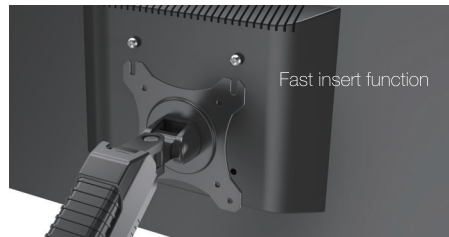

HOT

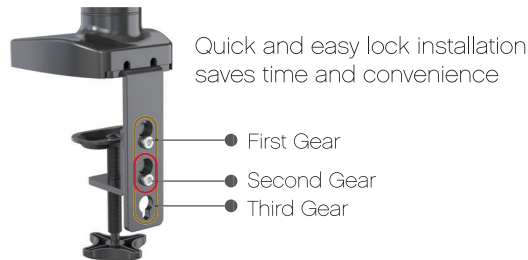
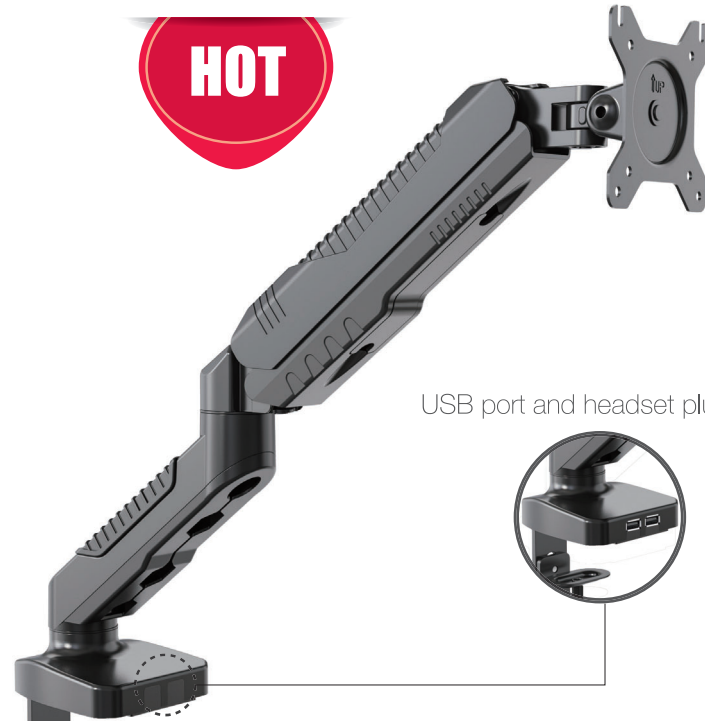

Model	VM-GC12	Features
Screen size	15"-27"	<ul style="list-style-type: none"> ● Durable gas spring arm ● Counter-balance height adjustment ● Fast insert function for monitor ● USB port integrated ● Angle-free tilt ● Clamp and grommet solution for different application
Max load	2-6.5kg/5-16.5lbs	
VESA	75x75/100x100	
Tilt	+90°/-85°	
Swivel	180°	
Rotate	360°	

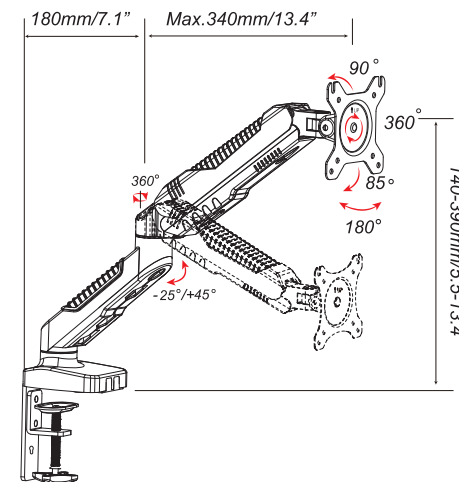

Gas Spring Wall Monitor Arm

Height adjustable working experience improves your working efficiency.



VM-GC12W

Screen size:15"-27"

Max load:2-6.5kg/5-16.5lbs

VESA:75x75/100x100

- Durable gas spring arm
- Counter-balance height adjustment
- Fast insert function for monitor
- Angle-free tilt

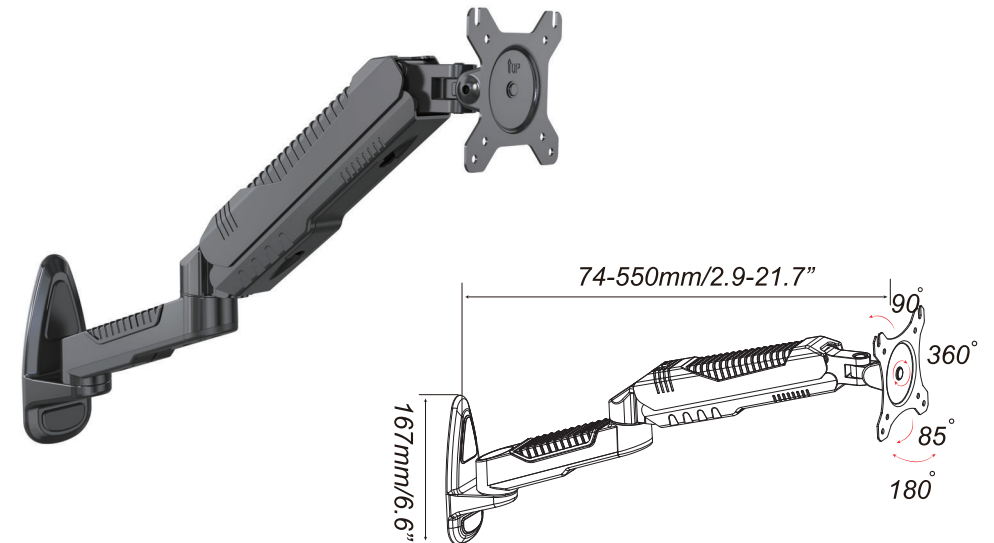

Gas Spring Monitor Arm

Height adjustable working experience improves your working efficiency.

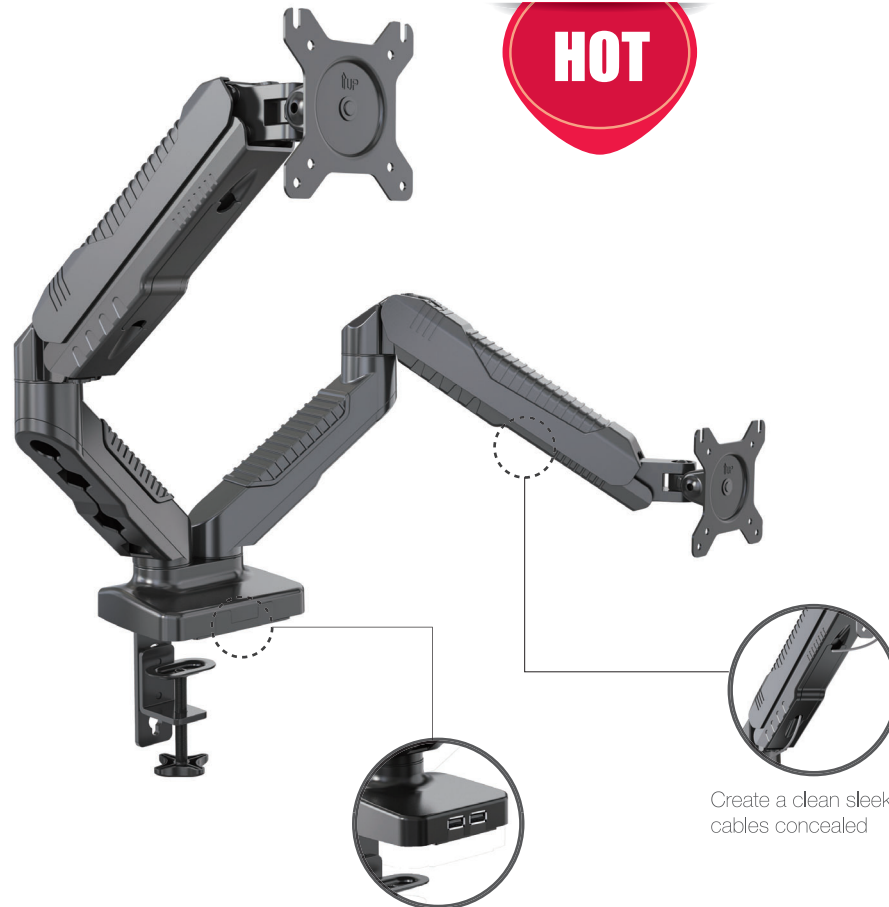
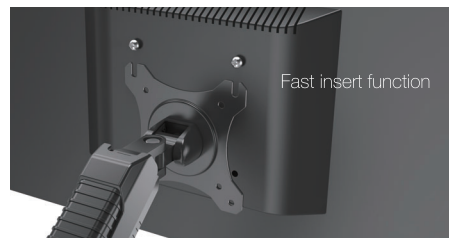

Model	VM-GC24	Features
Screen size	15"-27"	<ul style="list-style-type: none"> • Durable gas spring arm • Counter-balance height adjustment • Fast insert function for monitor • USB port integrated • Angle-free tilt • Clamp and grommet solution for different application
Max load	2-6.5kg/5-16.5lbs	
VESA	75x75/100x100	
Tilt	+90°/-85°	
Swivel	180°	
Rotate	360°	

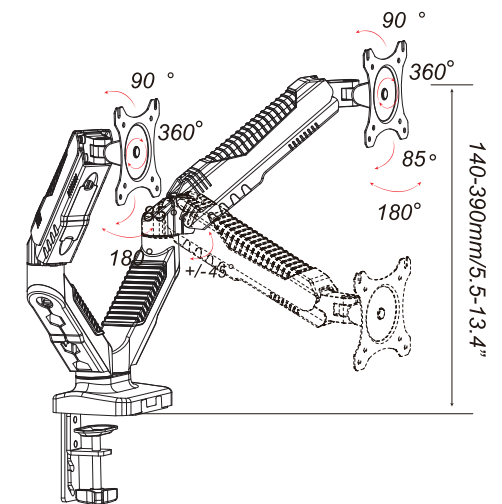

Gas Spring Monitor Arm

Gas spring arm with effortless height adjustment.



The wrench adjusts the inner damping screw to raise and lower the arm

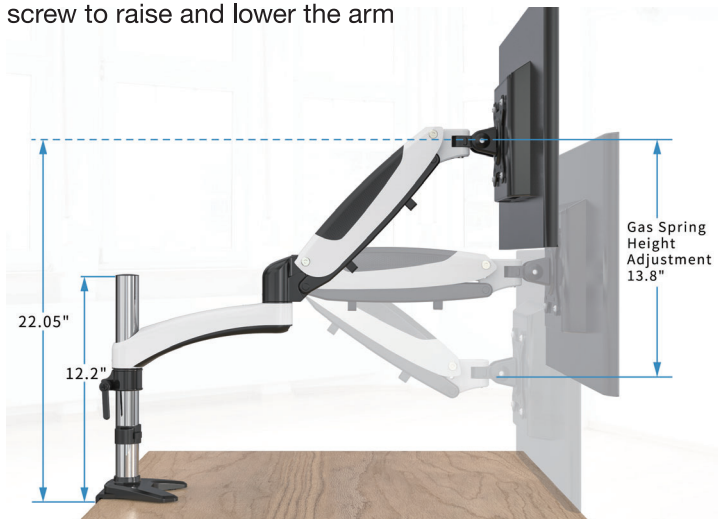

Desk clamp or grommet mounting available.

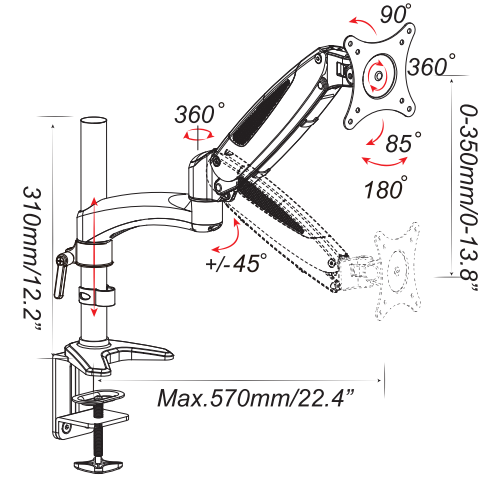

Model	VM-GM112D	Features
Screen size	15"-32"	<ul style="list-style-type: none"> Aluminum arm structure Support horizontal and vertical screen rotation to meet the needs of different occupations Gas spring arm with effortless height adjustment Angle-free tilt Clamp and grommet solution for different application
Max load	0-8kg/0-17.6lbs	
VESA	75x75/100x100	
Tilt	+90°/-85°	
Swivel	180°	
Rotate	360°	

Gas Spring Monitor Arm

Space-saving gas spring monitor arm, quick insert panel for easy office.

HOT

VISION / Gas Spring

keep steady & easy to control



Others / Mechanical Spring

hard to control spring tension



VM-GM112XD

Screen size:15"-35"

Max load:0-15kg/0-33lbs

VESA:75x75/100x100

- Gas spring arm with effortless height adjustment
- Aluminum arm structure
- Fast insert function for monitor
- Angle-free tilt



Quick Release
VESA Plate

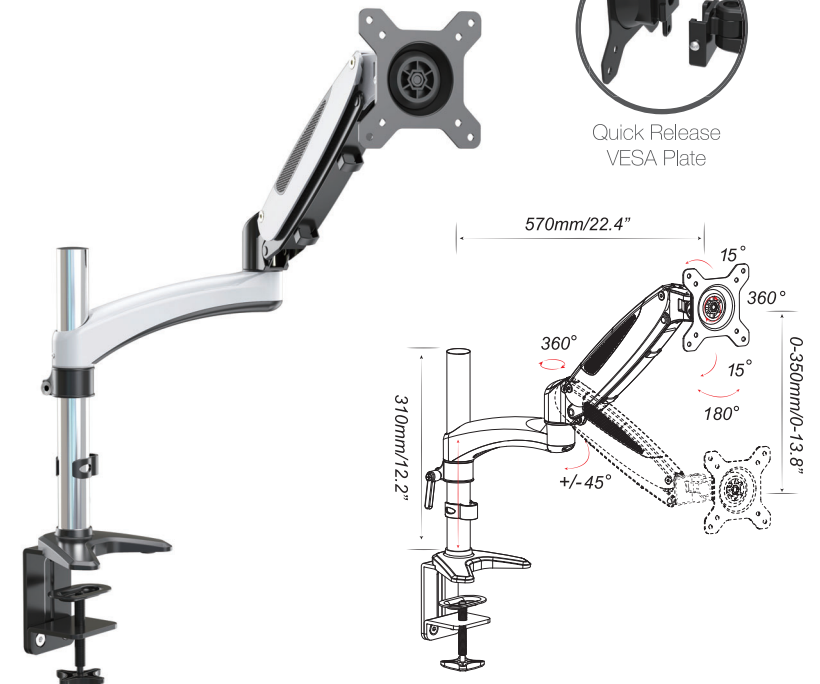

Gas Spring Monitor Arm

Gas spring arm with effortless height adjustment.

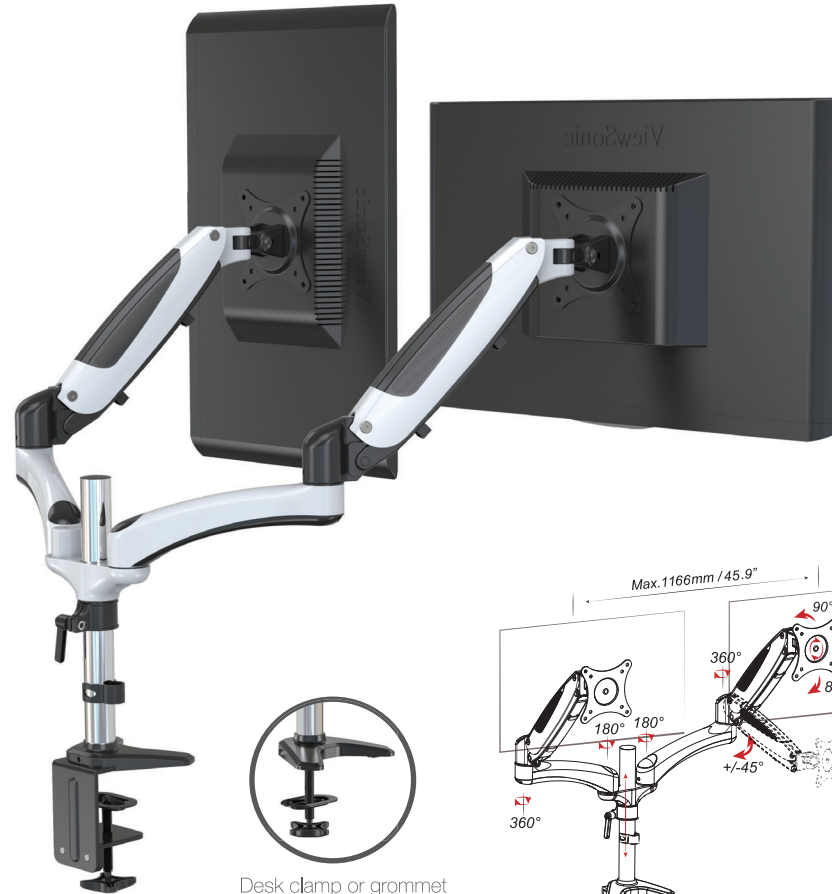
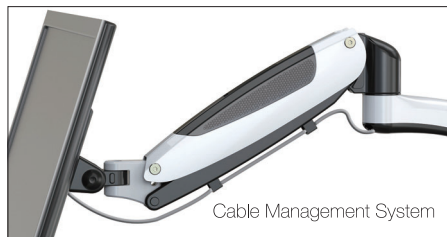
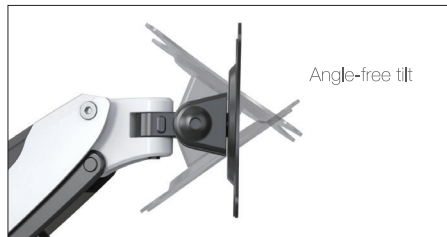

Desk clamp or grommet mounting available.

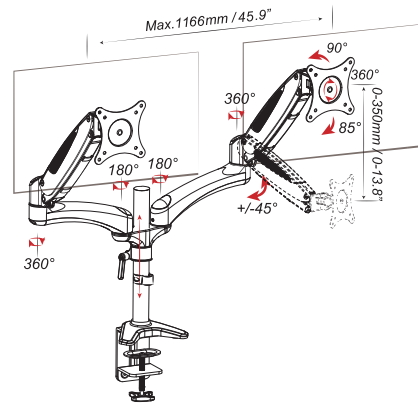

Model	VM-GM124D	Features
Screen size	15"-32"	<ul style="list-style-type: none"> Aluminum arm structure Support horizontal and vertical screen rotation to meet the needs of different occupations Gas spring arm with effortless height adjustment Angle-free tilt Clamp and grommet solution for different application
Max load	0-8kg/0-17.6lbs	
VESA	75x75/100x100	
Tilt	+90°/-85°	
Swivel	180°	
Rotate	360°	

Gas Spring Monitor Arm

Gas spring arm with effortless height adjustment.



The wrench adjusts the inner damping screw to raise and lower the arm



USB port and headset plug integrated



Grommet Mount
Fit Desk Thickness up to 2"

Clamp Mount
Fit Desk Thickness up to 3.35"

Model	VM-GM212U	Features
Screen size	15"-32"	<ul style="list-style-type: none"> Aluminum arm structure Support horizontal and vertical screen rotation to meet the needs of different occupations Gas spring arm with effortless height adjustment Angle-free tilt Clamp and grommet solution for different application
Max load	0-8kg/0-17.6lbs	
VESA	75x75/100x100	
Tilt	+90°/-85°	
Swivel	180°	
Rotate	360°	

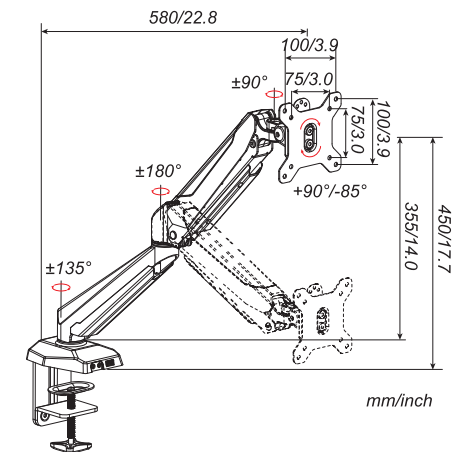
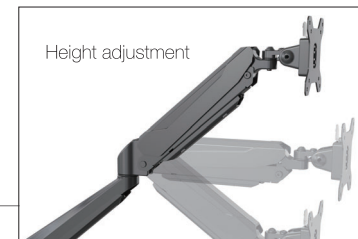

Gas Spring Monitor Arm

Gas spring arm with effortless height adjustment.

Flexible Monitor Positioning

Reach a comprehensive improvement of working efficiency

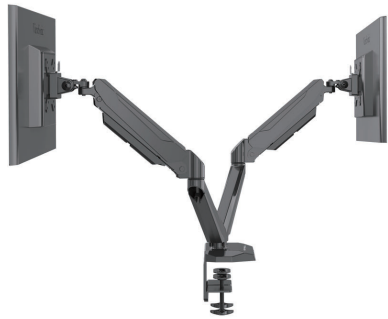

Back to back



Landscape and portrait



Both portrait



Widescreen



VM-GM224U

Screen size:15"-32"

Max load:0-8kg/0-17.6lbs

VESA:75x75/100x100

- Gas spring arm with effortless height adjustment
- Aluminum arm structure
- Fast insert function for monitor
- Angle-free tilt

Full Motion Monitor Arm

Up and down dual-screen monitoring, horizontal and vertical screen freely switch, easy to achieve work.



VM-FE120D

Screen size:15"-27"

Max load:0-8kg/0-17.6lbs

VESA:75x75/100x100

- 360 rotation allows portrait and landscape viewing
- Tool-less height adjustment for optimal viewing
- Head fast insert function
- Aluminum structure

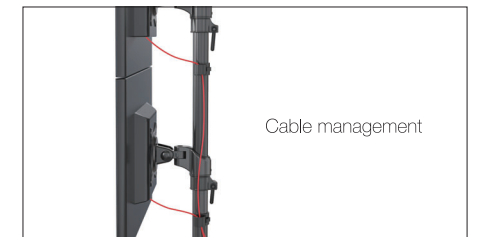

Full Motion Monitor Arm

Horizontal and vertical screen freely switch, easy to achieve work.

VM-FE110S

Screen size:15"-32"

Max load:0-8kg/0-17.6lbs

VESA:75x75/100x100

- 360 rotation allows portrait and landscape viewing
- Tool-less height adjustment for optimal viewing
- Head fast insert function
- Aluminum structure

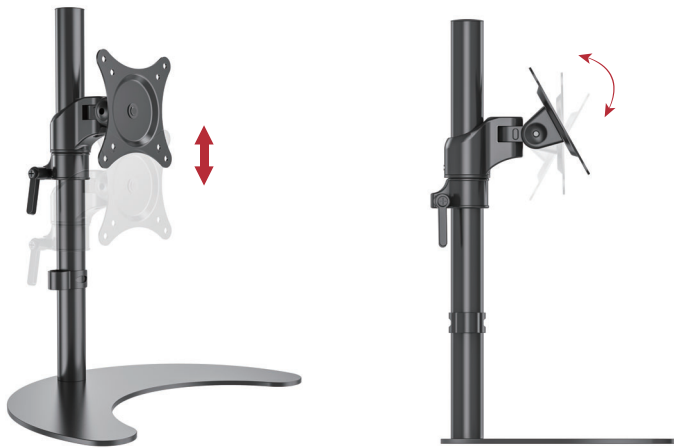

Cable management

Full Motion Monitor Arm

Horizontal and vertical screen freely switch, easy to achieve work.



VM-D28

Screen size: 13" - 32"

Max load: 8kg/17.6lbs

VESA: 75x75/100x100

- 360 rotation allows portrait and landscape viewing
- Tool-less height adjustment for optimal viewing
- High gauge cold rolled steel
- Steel Structure

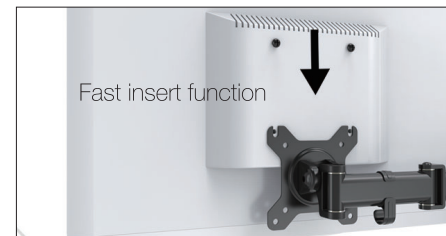
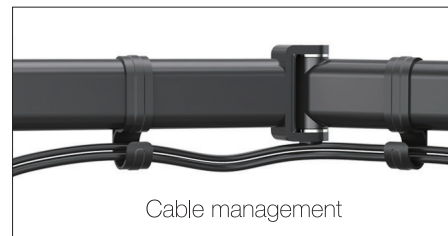
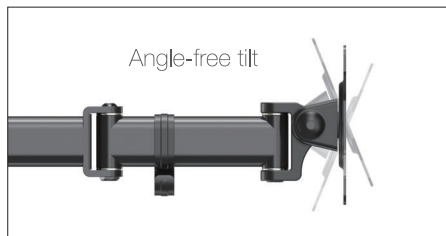

Full Motion Monitor Arm

Horizontal and vertical screen freely switch, easy to achieve work.

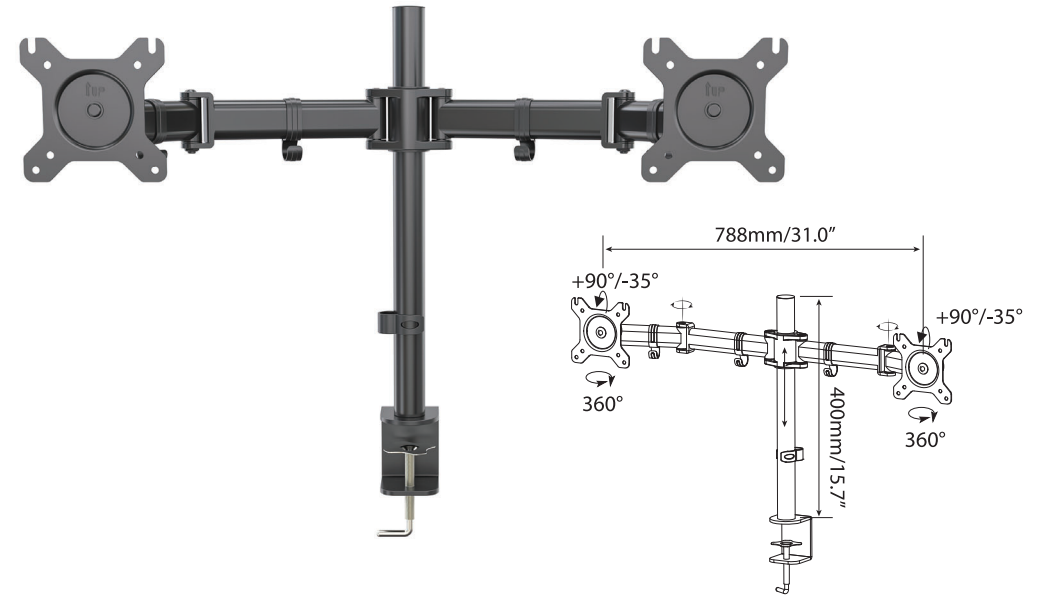

Model	VM-D29L	Features
Screen size	13"-32"	<ul style="list-style-type: none">● Save space without replacing the original desktop● Support horizontal and vertical screen rotation● Tool-less height adjustment for optimal viewing● Angle-free tilt● Steel Structure
Max load	8kg/17.6lbs	
VESA	75x75/100x100	
Tilt	+90°/-35°	
Swivel	180°	
Rotate	360°	

Full Motion Monitor Arm

Horizontal and vertical screen freely switch, easy to achieve work.

VM-D34S

Screen size: 15"-32"

Max load: 8kg/17.6lbs

VESA: 75x75/100x100

- 360 rotation allows portrait and landscape viewing
- Tool-less height adjustment for optimal viewing
- Support horizontal and vertical screen rotation
- Head fast insert function
- Steel Structure

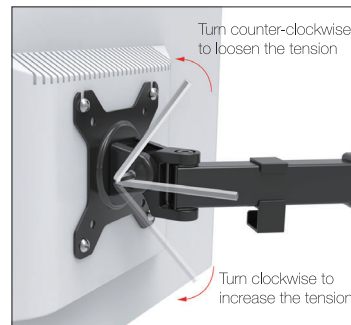
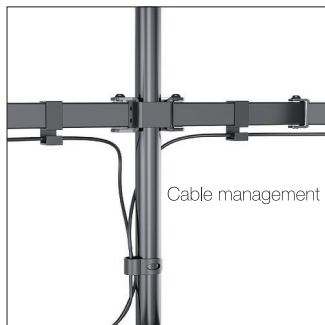

Multi Monitor Desk Mount

Multi-screen monitor display, Horizontal and vertical screen freely switch, easy to achieve work.

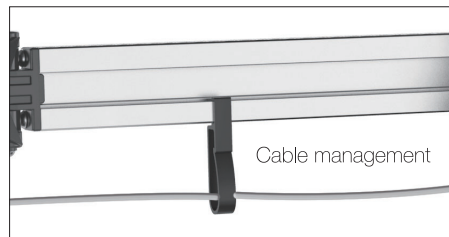
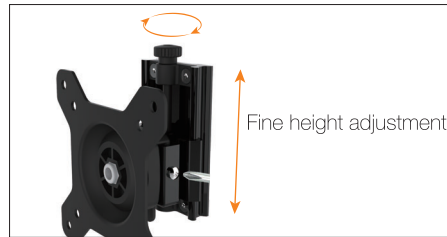
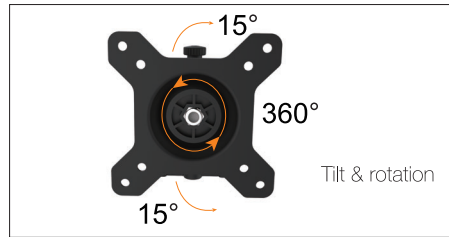
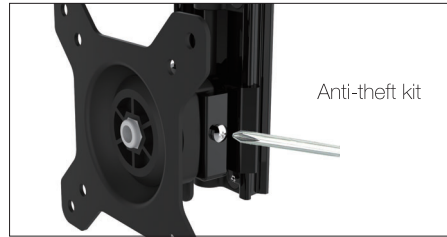

Multi Monitor Desk Mount

Multi-screen monitor display, Horizontal and vertical screen freely switch, easy to achieve work.

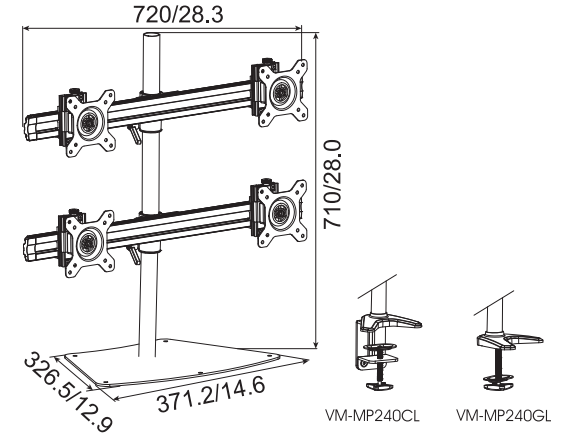
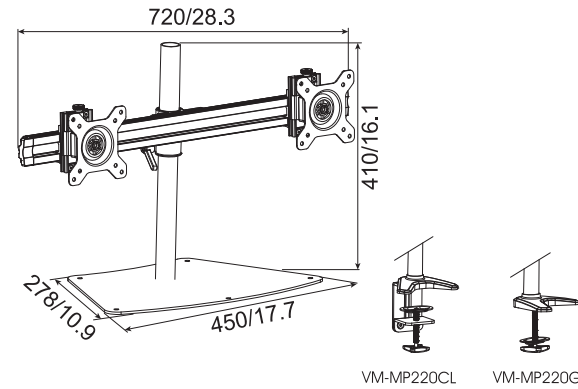
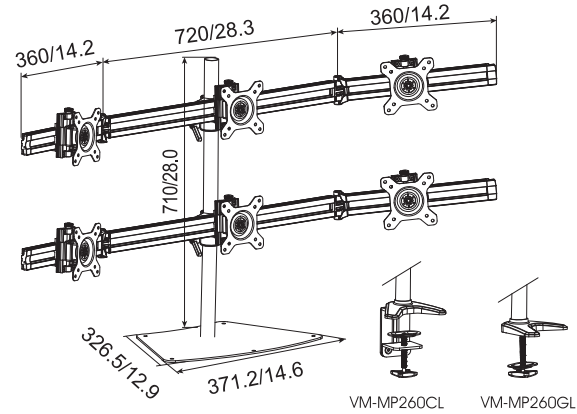
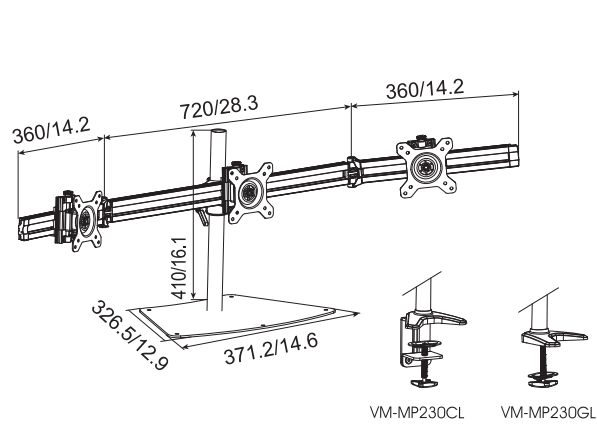

Model	VM-MP230SL
Screen size	15"-27"
Max load	8kg/17.6lbs
VESA	75x75/100x100
Tilt	+15°/-15°
Swivel	180°
Rotate	360°

Model	VM-MP260SL
Screen size	15"-27"
Max load	8kg/17.6lbs
VESA	75x75/100x100
Tilt	+15°/-15°
Swivel	180°
Rotate	360°

Model	VM-MP220SL
Screen size	15"-27"
Max load	8kg/17.6lbs
VESA	75x75/100x100
Tilt	+15°/-15°
Swivel	180°
Rotate	360°

Model	VM-MP240SL
Screen size	15"-27"
Max load	8kg/17.6lbs
VESA	75x75/100x100
Tilt	+15°/-15°
Swivel	180°
Rotate	360°

Multi Monitor Desk Mount

Multi-screen monitor display, Horizontal and vertical screen freely switch, easy to achieve work.

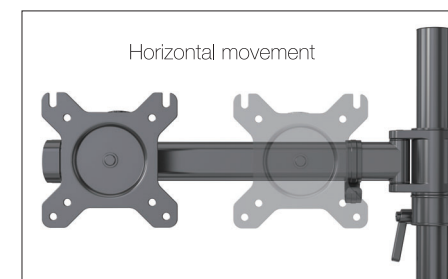
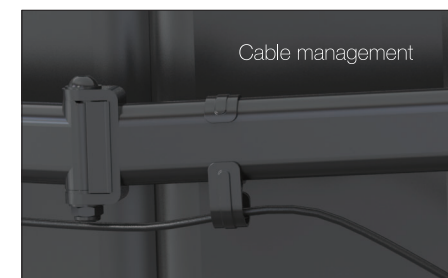
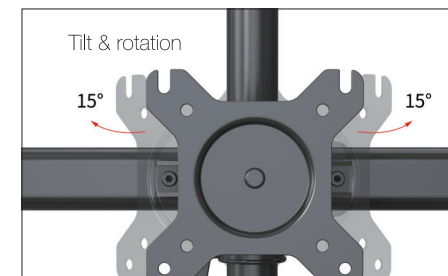

Multi Monitor Desk Mount

Multi-screen monitor display, Horizontal and vertical screen freely switch, easy to achieve work.

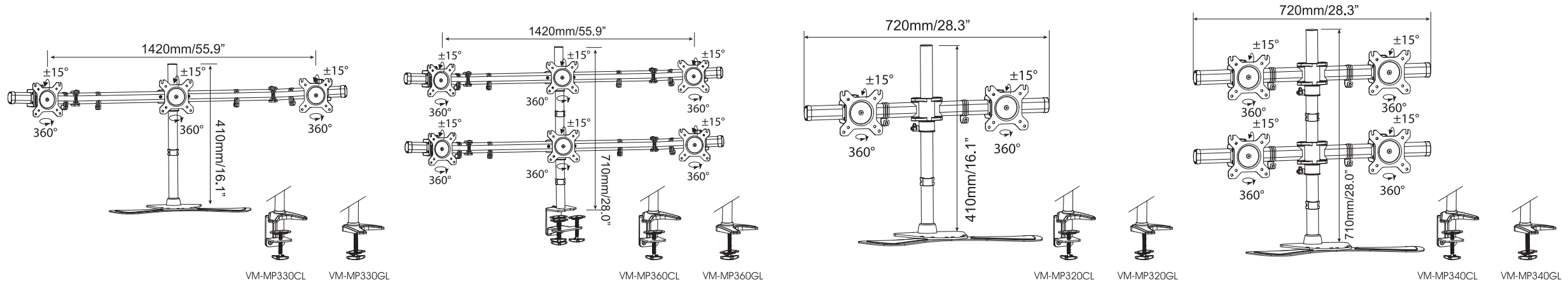

Model	VM-MP330SL
Screen size	15"-27"
Max load	8kg/17.6lbs
VESA	75x75/100x100
Tilt	+15°/-15°
Swivel	180°
Rotate	360°

Model	VM-MP360SL
Screen size	15"-27"
Max load	8kg/17.6lbs
VESA	75x75/100x100
Tilt	+15°/-15°
Swivel	180°
Rotate	360°

Model	VM-MP320SL
Screen size	15"-27"
Max load	8kg/17.6lbs
VESA	75x75/100x100
Tilt	+15°/-15°
Swivel	180°
Rotate	360°

Model	VM-MP340SL
Screen size	15"-27"
Max load	8kg/17.6lbs
VESA	75x75/100x100
Tilt	+15°/-15°
Swivel	180°
Rotate	360°

Office Desk Mount Solution

Height adjustable working experience improves your working efficiency.

Intelligent product range for individual solutions.



VM-AP14T

OMA01x2+OMA03x2+OMA05+D15+
OMA06+OMA08+OMA09x2+OMA10



VM-AP18

OMA11+OMA12+OMA13+
OMA14+OMA15+OMA17

Office Desk Mount Solution

Height adjustable working experience improves your working efficiency.

Aluminum Column for Desk Clamp
Model No. OMA01



400mm



Aluminum Slat Wall Element
Model No. OMA03

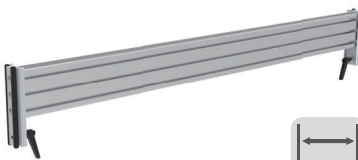

1000mm

Single Monitor Plate for Slat Wall
Model No. OMA04



13"-32"
Most

8kg/17.6lbs

75x75, 100x100
VESA



Gas Spring Aluminum Arm
Model No. OMA05



13"-32"
Most

8kg/17.6lbs

75x75, 100x100
VESA



Full Motion Aluminum Arm
Model No. OMA06



13"-32"
Most



8kg/17.6lbs

75x75, 100x100
VESA



413mm

Single Monitor Plate for Column
Model No. OMA07

125mm

Metal Pen Holder
Model No. OMA08
H120xW75xD70mm



OMA08

Model No. OMA13
H100xW80xD80mm



OMA13



Metal File Tray
Model No. OMA09
H62xW300xD220mm



OMA09

Model No. OMA14
H57xW300xD201mm



OMA14

Metal Folder Shelf
Model No. OMA10
H303xW122xD255mm



OMA10

Model No. OMA12
H310xW100xD221mm



OMA12



Aluminum Column for Desk Clamp
Model No. OMA11



1203mm

Single Monitor Plate for Slat Wall

OMA15



OMA16



13"-32"
Most

8kg/17.6lbs

75x75, 100x100
VESA

Gas Spring Aluminum Arm

OMA17



OMA18



13"-32"
Most

8kg/17.6lbs

75x75, 100x100
VESA



Monitor Mount for Standing Desktop

Provide best viewing angles for sit & stand experience.

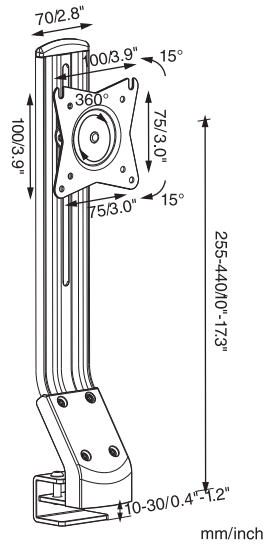
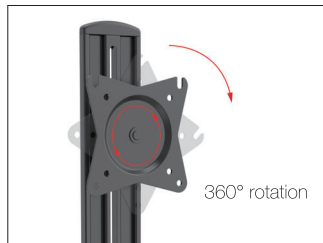
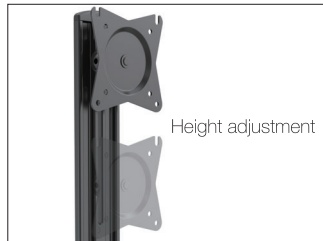

Model	VM-LDS01
Screen size	13"-27"
Max load	8kg/17.6lbs
VESA	75x75/100x100
Tilt	+15°/-15°
Swivel	180°
Rotate	360°

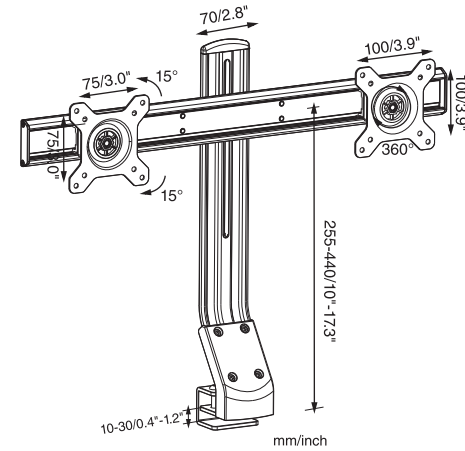

Model	VM-LDS02
Screen size	13"-27"
Max load	8kg/17.6lbs
VESA	75x75/100x100
Tilt	+15°/-15°
Swivel	180°
Rotate	360°

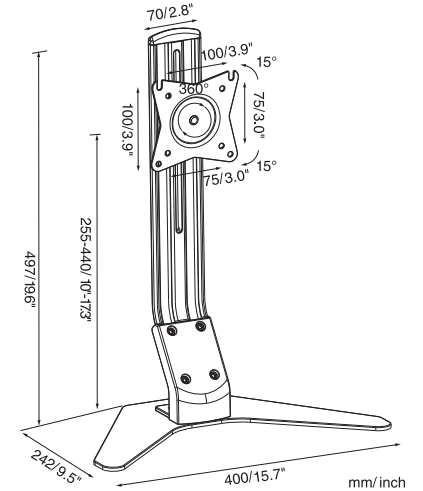

Model	VM-LDS03
Screen size	13"-27"
Max load	8kg/17.6lbs
VESA	75x75/100x100
Tilt	+15°/-15°
Swivel	180°
Rotate	360°

Work Station Monitor Arm

Space-saving gas spring monitor arm, quick insert panel for easy office.



HOT



Work Station Monitor Arm

Gas spring arm with effortless height adjustment.

WS21 workstation, smooth adjustment, free movement without gears, full-scale free hovering, anti-rust aluminum alloy body, high-end quality assurance, tilting groove design for easy placement of mobile phones, providing convenient operation.

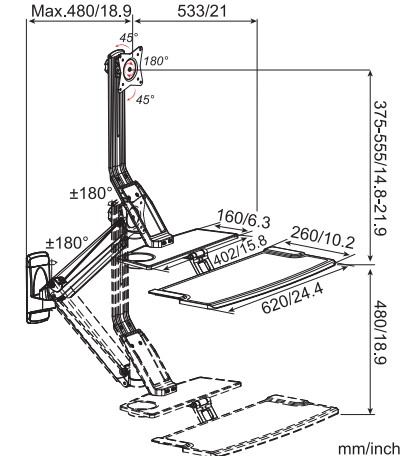
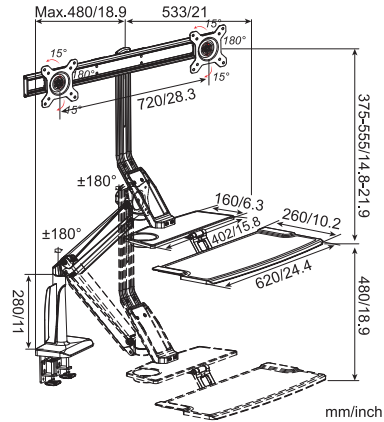
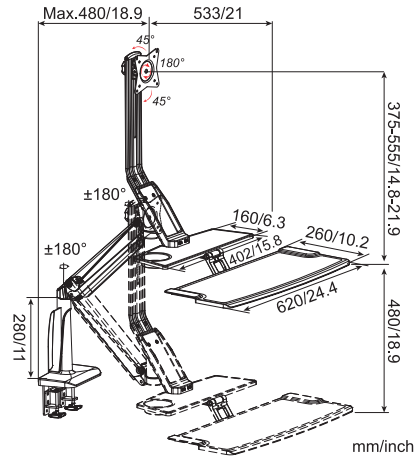

Model	VM-WS21E
Screen size	17"-32"
Max load	1.5-9kg/3.3-19.8lbs
VESA	75x75/100x100
Tilt	+45°/-45°
Swivel	180°
Rotate	360°

Model	VM-WS22E
Screen size	17"-32"
Max load	3-16kg/6.6-35.2lbs
VESA	75x75/100x100
Tilt	+15°/-15°
Swivel	180°
Rotate	360°

Model	VM-WS21W
Screen size	17"-32"
Max load	1.5-9kg/3.3-19.8lbs
VESA	75x75/100x100
Tilt	+45°/-45°
Swivel	180°
Rotate	360°

Laptop Monitor Arm

Stay healthy to sit and stand experience.



Laptop Monitor Arm

Stay healthy to sit and stand experience.

Laptop and monitor usage at the same time
 Angle freely adjustable for best working view
 Space saving with best management

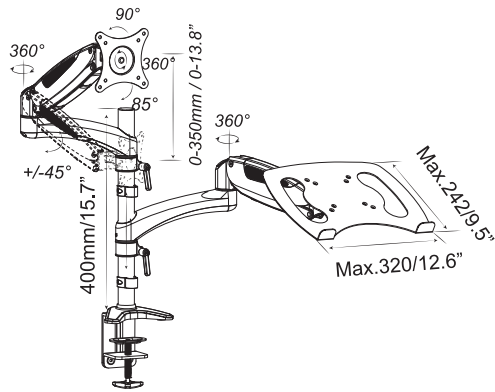

Model	VM-LH08
Screen size	15"-32"
Max load	8kg/17.6lbs
VESA	75x75/100x100
Tilt	+90°/-85°
Swivel	180°
Rotate	360°

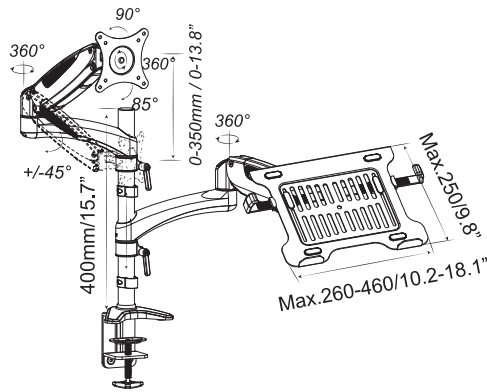

Model	VM-LH08+LH03
Screen size	15"-32"
Max load	8kg/17.6lbs
VESA	75x75/100x100
Tilt	+90°/-85°
Swivel	180°
Rotate	360°

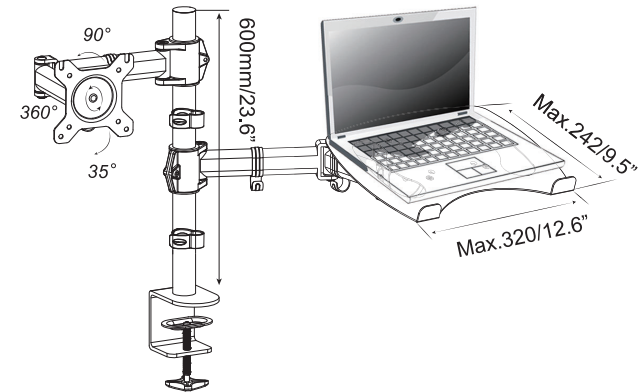

Model	VM-LH07
Screen size	15"-32"
Max load	8kg/17.6lbs
VESA	75x75/100x100
Tilt	+90°/-85°
Swivel	180°
Rotate	360°

Laptop Monitor

Max load:8kg/17.6lbs

Compatible with all our gas spring mounts

Solid steel laptop holder with standard VESA mounting holes

Laptop holder compatible with most mounts,also fit for other mounts



Laptop and Document Holder

Max load:10kg/22lbs

Move to any location you want.

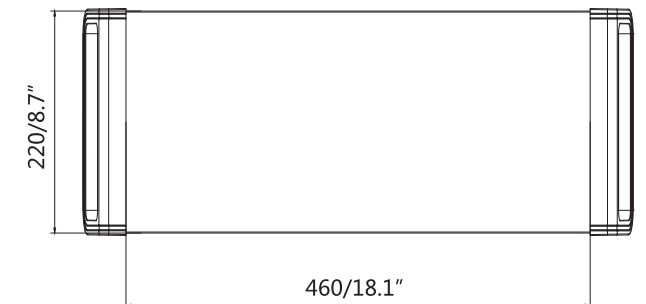
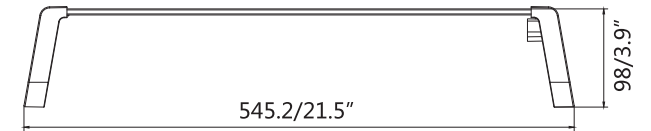
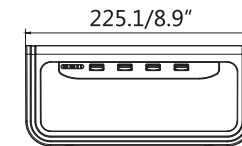
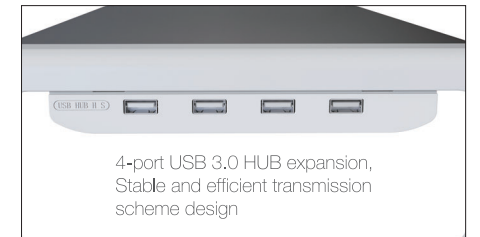



THANK YOU!